



---

**FS-1120D**  
**FS-1320D**  
**ECOSYS P2035d**  
**ECOSYS P2135d**  
**PARTS LIST**

Published in October 2013  
2LZPL071  
842LZ121  
Rev.1

———— CONTENTS ————

FIG. 1 Covers ..... 2  
FIG. 2 Frames ..... 4  
FIG. 3 Paper Cassette ..... 6  
FIG. 4 Paper Feed Section 1 ..... 8  
FIG. 5 Paper Feed Section 2 ..... 10  
FIG. 6 Image Formation Section ..... 12  
FIG. 7 Developing Section ..... 14  
FIG. 8 Fuser Section ..... 16  
FIG. 9 Drive Section ..... 18  
FIG. 10 Duplex Section ..... 20  
FIG. 11 Electrical Components ..... 22  
FIG. 12 Maintenance Kits ..... 24

• INDEX ..... 25

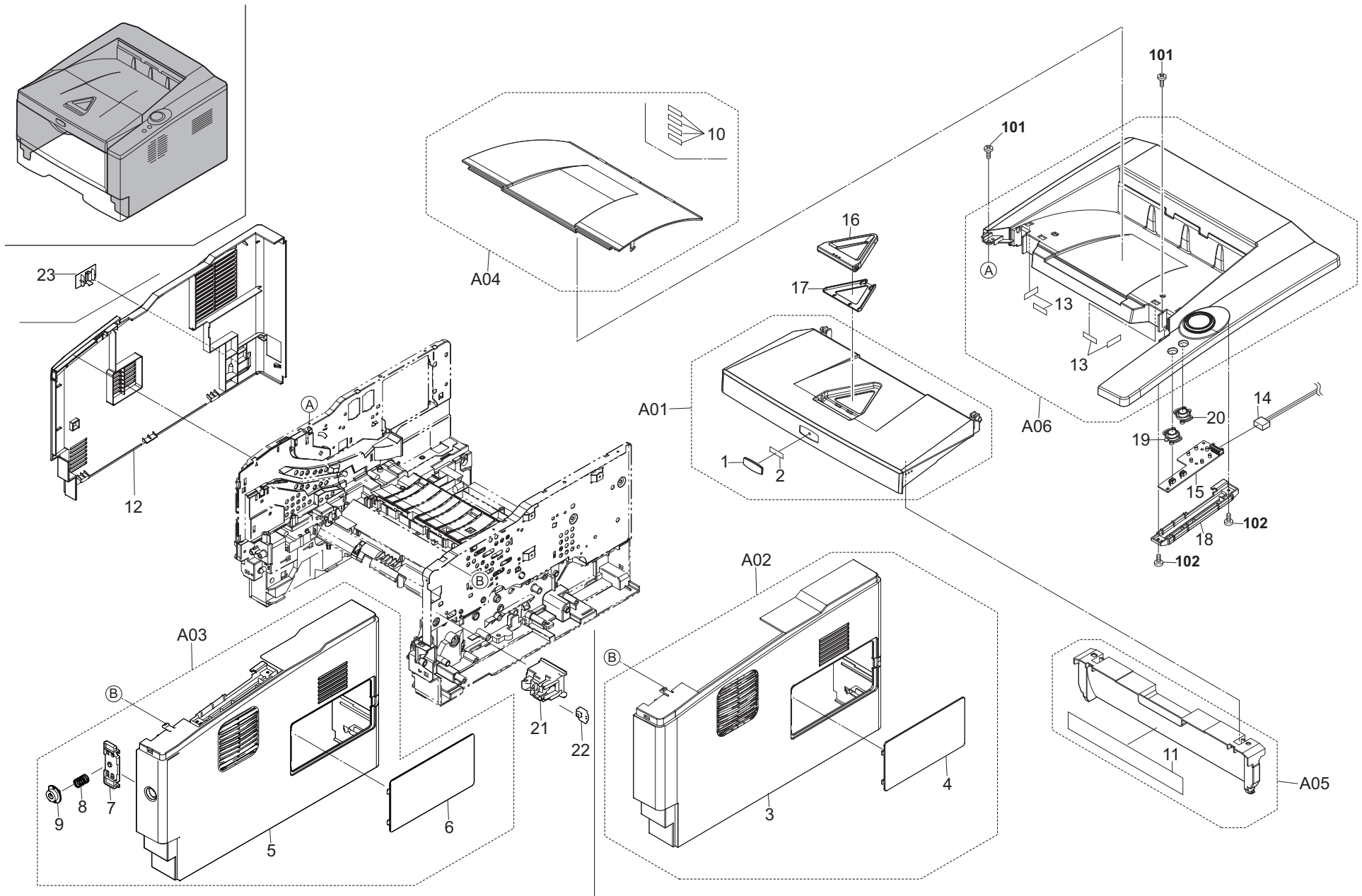

FIG. 1 Covers

2LY/2LZ/2PG/2PH-1

Ref. No.	Part.No.	Alternative.	Description	Notes	Quantity		
					120	230	240
⊙ A01	302HS94020	2HS94020	LID TOP ASSY		1	1	1
1	*302F904120	2F904120	EMBLEM KYOCERA		1	1	1
2	*302F904130	2F904130	TAPE EMBLEM		1	1	1
⊙ A02	302LY00010	2LY00010	COVER RIGHT ASSY	1120D	1	1	1
⊙ A02	302LZ00010	2LZ00010	COVER RIGHT ASSY	1320D	1	1	1
⊙ A02	302PG00020	2PG00020	COVER RIGHT ASSY	P2035d	1	1	1
⊙ A02	302PH00020	2PH00020	COVER RIGHT ASSY	P2135d	1	1	1
3	*302LY04010	2LY04010	COVER RIGHT	1120D	1	1	1
3	*302LZ04020	2LZ04020	COVER RIGHT	1320D	1	1	1
3	*302PG04020	2PG04020	COVER RIGHT	P2035d	1	1	1
3	*302PH04010	2PH04010	COVER RIGHT	P2135d	1	1	1
4	*302LZ04030	2LZ04030	COVER DIMM		1	1	1
⊙ A03	302LY94030	2LY94030	PARTS COVER RIGHT 2 ASSY SP	1120D	1		
⊙ A03	302LZ94140	2LZ94140	PARTS COVER RIGHT 2 ASSY SP	1320D	1		
⊙ A03	302PG94010	2PG94010	PARTS COVER RIGHT 2 ASSY SP	P2035d	1		
⊙ A03	302PH94010	2PH94010	PARTS COVER RIGHT 2 ASSY SP	P2135d	1		
5	*302LY04020	2LY04020	COVER RIGHT 2	1120D	1		
5	*302LZ04080	2LZ04080	COVER RIGHT 2	1320D	1		
5	*302PG04030	2PG04030	COVER RIGHT 2	P2035d	1		
5	*302PH04020	2PH04020	COVER RIGHT 2	P2135d	1		
6	*302LZ04030	2LZ04030	COVER DIMM		1		
7	*302LZ04070	2LZ04070	HOLDER KEY SW		1		
8	*302F931270	2F931270	SPRING FUSER		1		
9	*302LZ04060	2LZ04060	KEY POWER		1		
⊙ A04	302HS94140	2HS94140	COVER TOP B KIT SP		1	1	1
10	*302HS04170	2HS04170	SHEET TOP COVER		4	4	4
⊙ A05	302HS94121	2HS94121	COVER FRONT ASSY (2HS) SP		1	1	1
11	*302HS34080	2HS34080	LABEL JAM TK OPERATION		1	1	1
⊙ 12	302LZ04011	2LZ04011	COVER LEFT		1	1	1
⊙ A06	302HS94010	2HS94010	COVER TOP ASSY		1	1	1
13	*302HS04170	2HS04170	SHEET TOP COVER		4	4	4
14	302HS46230	2HS46230	CONN.CORD ASSY PANEL-RELAY S03353		1	1	1
15	302HS01030	2HS01030	P.W.B BOARD ASSY PANEL		1	1	1
⊙ 16	302HS04070	2HS04070	COVER RACK		1	1	1
⊙ 17	302HS04160	2HS04160	COVER RACK B		1	1	1
18	302HS04080	2HS04080	COVER PANEL		1	1	1
19	302HS04100	2HS04100	BUTTON ENTER	1120D, 1320D	1	1	1
19	302PG04070	2PG04070	BUTTON ENTER	P2035d, P2135d	1	1	1
20	302HS04110	2HS04110	BUTTON CANCEL		1	1	1
21	302LZ04050	2LZ04050	MOUNT PWB SW		1		
⊙ 22	302LZ94180	2LZ94180	PARTS PWB ASSY SWITCH SP		1		
23	302LZ04090	2LZ04090	COVER MAIN SW		1		

Ref. No.	Part.No.	Alternative.	Description	Notes	Quantity		
					120	230	240
101	7BB200410H	BB105700	+BIND T.T P SCREW 4X10				
102	7BB200308H	BB105660	+BIND T.T P SCREW 3X8				

- Parts with "⊙" indicate regular maintenance parts.
- Parts with Ref.No. indicate maintenance parts and the ones without it indicate out of the above.

- Parts with "\*" are component parts or sub-assemblies of the assembly appearing immediately above them.
- Parts with "••" are component parts or sub-assembly with "•" appearing immediately above them.

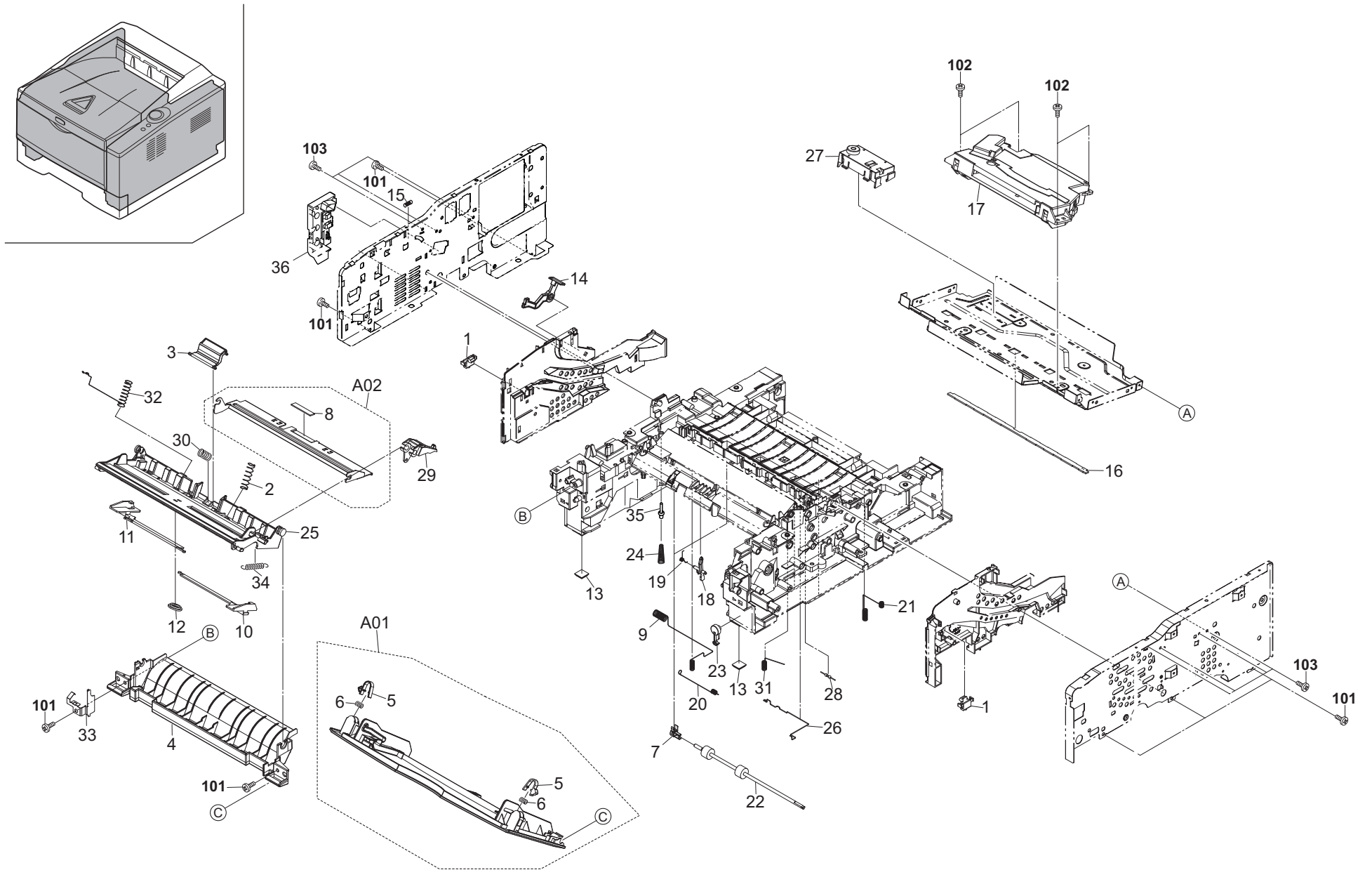

FIG. 2 Frames

2LY/2LZ/2PG/2PH-1

Ref. No.	Part.No.	Alternative.	Description	Notes	Quantity		
					120	230	240
⊙	1	302F902420	2F902420		2	2	2
	2	302F908270	2F908270		1	1	1
⊙	3	302HS94040	2HS94040		1	1	1
	4	302LZ08020	2LZ08020		1	1	1
⊙	A01	302LZ94090	2LZ94090		1	1	1
	5	*302F908200	2F908200		2	2	2
⊙	6	*302HS08320	2HS08320		2	2	2
	7	302HS24130	2HS24130		2	2	2
⊙	A02	302HS94050	2HS94050		1	1	1
	8	*302F908310	2F908310		1	1	1
⊙	9	302HS02160	2HS02160		1	1	1
	10	302HS08241	2HS08241		1	1	1
⊙	11	302HS08251	2HS08251		1	1	1
	12	5MVG137DN032	2A806720		1	1	1
⊙	13	302J002010	2J002010		2	2	2
	14	302HS02090	2HS02090		1	1	1
⊙	15	302HS02100	2HS02100		1	1	1
	16	302H494020	2H494020	1120D	1	1	1
⊙	16	302LZ94010	2LZ94010	1320D, P2035d, P2135d	1	1	1
	17	302LY93030	2LY93030	1120D	1	1	1
⊙	17	302LZ93030	2LZ93030	1320D, P2035d, P2135d	1	1	1
	18	302LZ24030	2LZ24030		1	1	1
⊙	19	302HS24070	2HS24070		1	1	1
	20	302H402060	2H402060		1	1	1
⊙	21	302HS02330	2HS02330		1	1	1
	22	302HS24160	2HS24160		2	2	2
⊙	23	302HS02650	2HS02650		1	1	1
	24	302HS02470	2HS02470		1	1	1
⊙	25	302HS08050	2HS08050		1	1	1
	26	302H402040	2H402040		1	1	1
⊙	27	302H994360	2H994360		1	1	1
	28	7RHA2H10701+H01	RH043740		1	1	1
⊙	29	302HS08100	2HS08100		1	1	1
	30	302HS08170	2HS08170		1	1	1
⊙	31	302HS24300	2HS24300		1	1	1
	32	302HS08210	2HS08210		1	1	1
⊙	33	302HS08230	2HS08230		1	1	1
	34	302HS08270	2HS08270		1	1	1
⊙	35	302HS02461	2HS02461		1	1	1
	36	302HS94281	2HS94281		1	1	1

Ref. No.	Part.No.	Alternative.	Description	Notes	Quantity		
					120	230	240
⊙	101	7BB200410H	BB105700				
	102	7BB600308H	BB055190				
	103	7BB100306H1	BB105820				

- Parts with "⊙" indicate regular maintenance parts.
- Parts with Ref.No. indicate maintenance parts and the ones without it indicate out of the above.

- Parts with "\*" are component parts or sub-assemblies of the assembly appearing immediately above them.
- Parts with "••" are component parts or sub-assembly with "•" appearing immediately above them.

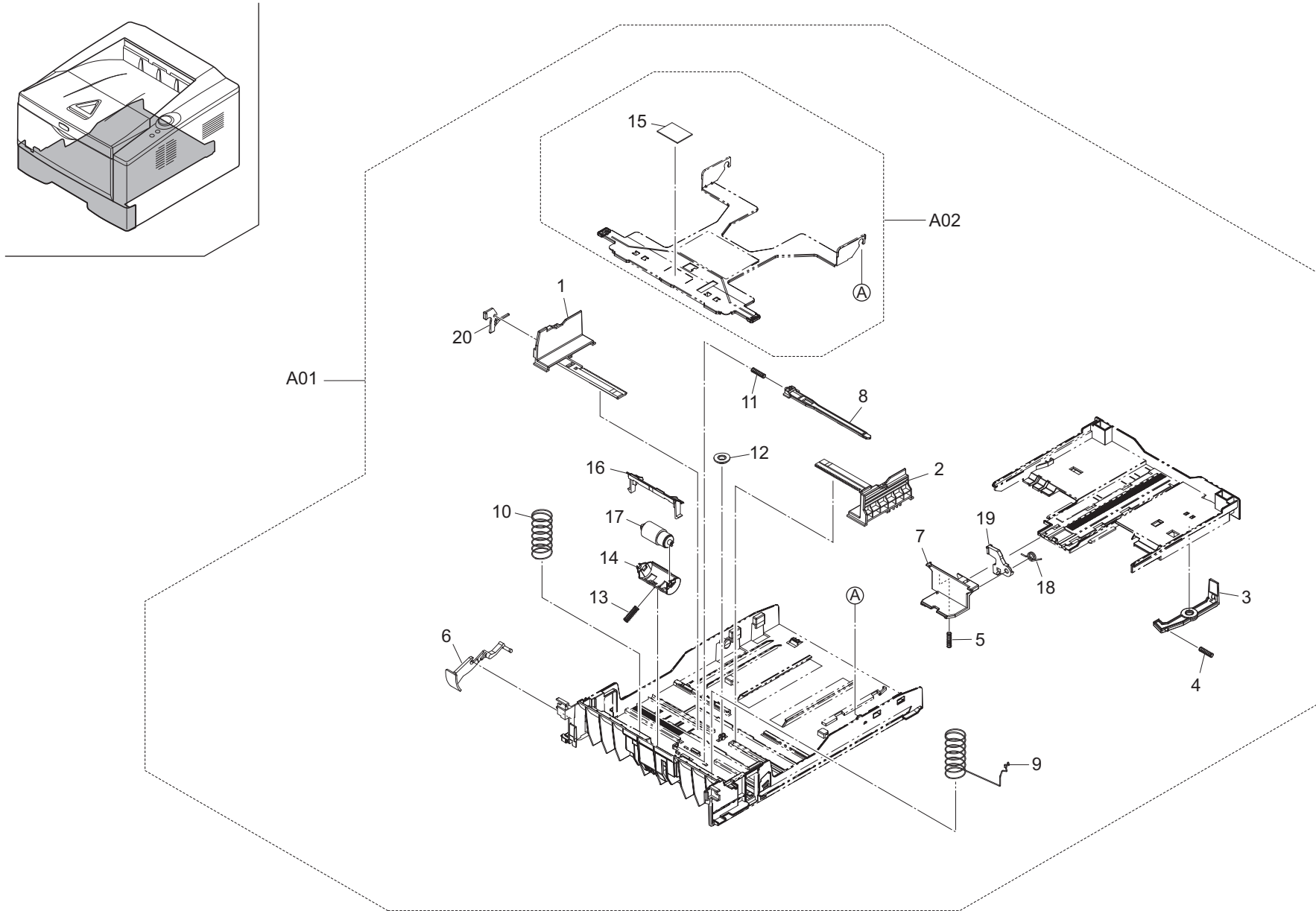

FIG. 3 Paper Cassette

2LY/2LZ/2PG/2PH-1

Ref. No.	Part.No.	Alternative.	Description	Notes	Quantity		
					120	230	240
⊙ A01	302LZ93071	2LZ93071	CT-170		1	1	1
1	*2FM06010	5MVX765SH004	GUIDE SIDE L /B-11 CASSETTE A2		1	1	1
2	*2FM06020	5MVX765SH005	GUIDE SIDE R /B-11 CASSETTE A2		1	1	1
3	*302F909031	2F909031	LEVER BASE CAS REAR		1	1	1
4	*302F909040	2F909040	SPRING BASE CAS REAR		1	1	1
5	*302HN09190	2HN09190	SPRING FIX		1	1	1
6	*302HS09070	2HS09070	PAPER INDICATOR		1	1	1
7	*302HS09081	2HS09081	CURSOR END		1	1	1
8	*302HS09100	2HS09100	LOCK BOTTOM		1	1	1
9	*302HS09120	2HS09120	SPRING BOTTOM L		1	1	1
10	*302HS09130	2HS09130	SPRING BOTTOM R		1	1	1
11	*302HS09140	2HS09140	SPRING LOCK BOTTOM		1	1	1
12	*302HS09160	2HS09160	GEAR CASSETTE		1	1	1
13	*302HS09180	2HS09180	SPRING RETARD		1	1	1
14	*302HS09260	2HS09260	HOLDER RETARD		1	1	1
⊙ A02	*302HS94000	2HS94000	PLATE BOTTOM ASSY		1	1	1
15	**302F909210	2F909210	PAD BOTTOM		1	1	1
16	*302LZ09030	2LZ09030	GUIDE RETARD		1	1	1
⊙ 17	*302BR06521	2BR06521	RETARD ROLL ASSY /43487V0005 A4		1	1	1
18	*5MMW171LD006	2A807530	SPRING STOPPER /A49 CASSETTE A4		1	1	1
19	*5MVX541DG002	2A807191	LEVER REAR /A-49 CASSETTE A3		1	1	1
20	*5MVX541DG003	2A807161	LEVER SIDE /A-49 CASSETTE A3		1	1	1

- Parts with "⊙" indicate regular maintenance parts.
- Parts with Ref.No. indicate maintenance parts and the ones without it indicate out of the above.

- Parts with "\*" are component parts or sub-assemblies of the assembly appearing immediately above them.
- Parts with "• •" are component parts or sub-assembly with "•" appearing immediately above them.



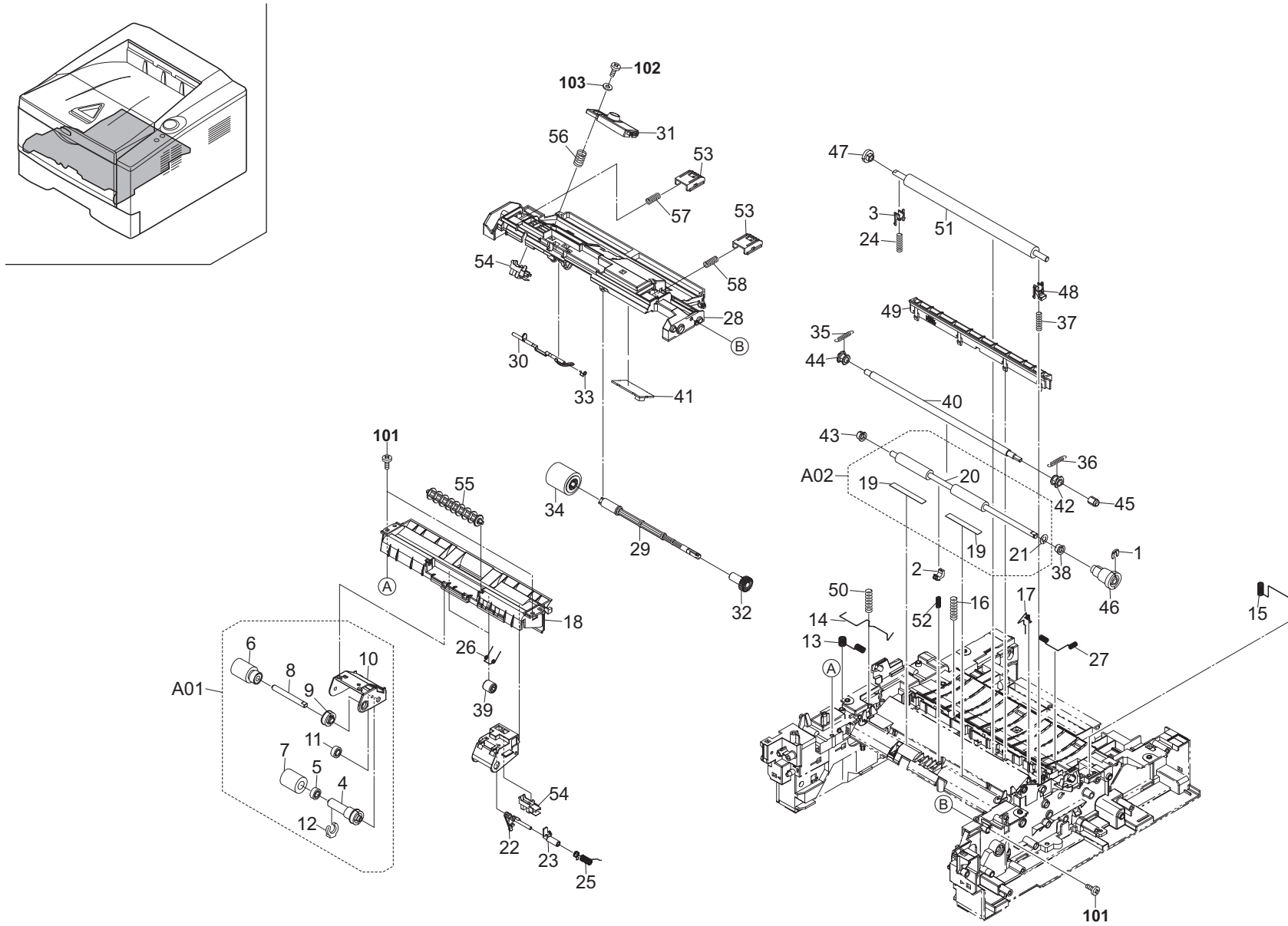



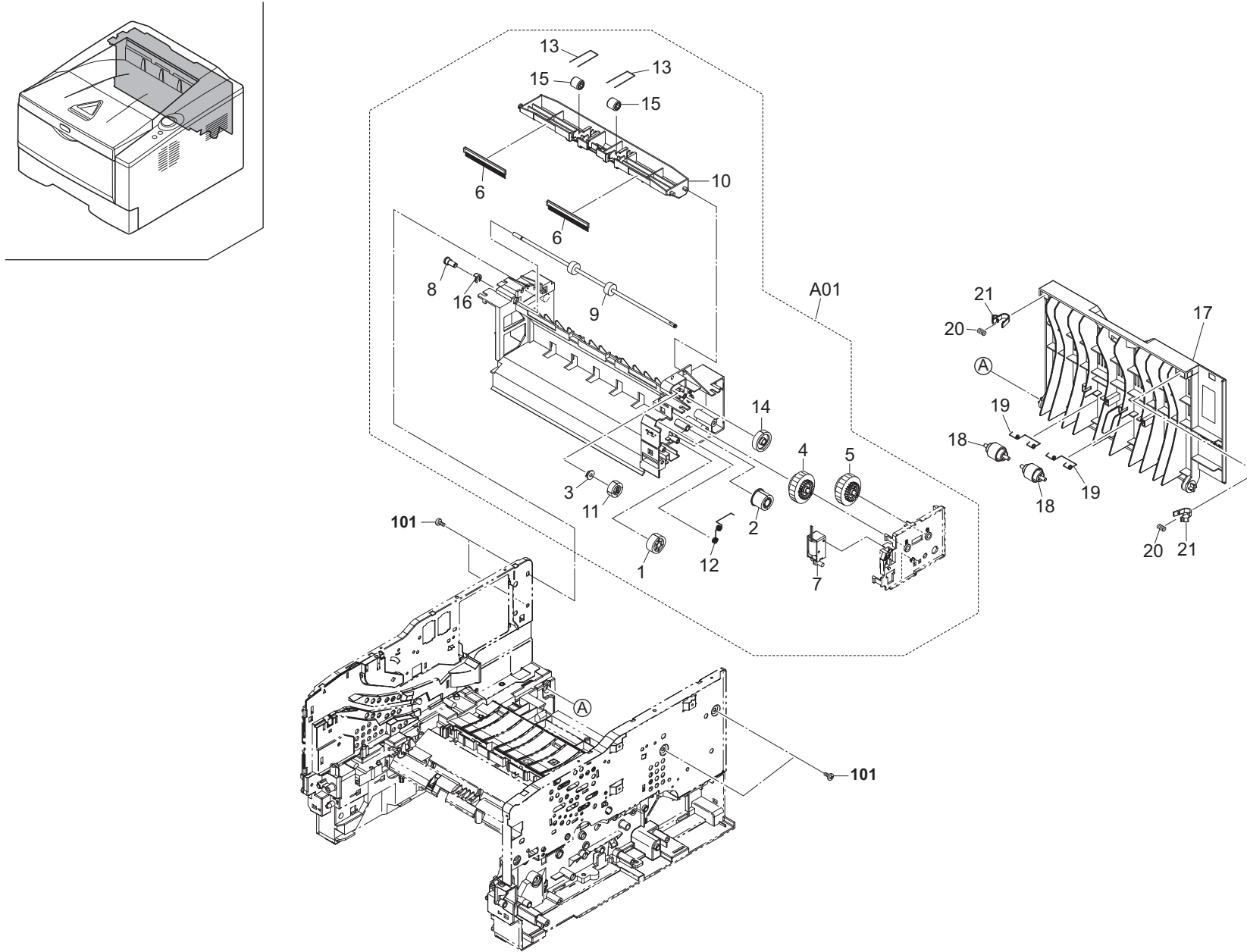

FIG. 5 Paper Feed Section 2

2LY/2LZ/2PG/2PH-1

Ref. No.	Part.No.	Alternative.	Description	Notes	Quantity		
					120	230	240
⊙ A01	302LZ94100	2LZ94100	PARTS FD ASSY (2LZ) SP		1	1	1
⊙ 1	*2BL06380	2BL06380	GEAR Z25 JOINT		1	1	1
⊙ 2	*2FM02350	5MVG133DN022	GEAR Z22 /B-11 FRAME A4		1	1	1
⊙ 3	*302F929140	2F929140	BUSH DU		1	1	1
⊙ 4	*302FM94020	2FM94020	GEAR CLUTCH ASSY A SP		1	1	1
⊙ 5	*302FM94030	2FM94030	GEAR CLUTCH ASSY B SP		1	1	1
⊙ 6	*302H428020	2H428020	DISCHARGER FD		2	2	2
⊙ 7	*302H494070	2H494070	SOLENOID ASSY SP		1	1	1
⊙ 8	*302HN29050	2HN29050	BUSH DU		1	1	1
⊙ 9	*302HS28830	2HS28830	ROLLER FD UP B		1	1	1
10	*302HS28041	2HS28041	COVER FD		1	1	1
⊙ 11	*302HS28060	2HS28060	GEAR Z21S		1	1	1
12	*302HS28110	2HS28110	SPRING EARTH		1	1	1
13	*302HS28141	2HS28141	SPRING PULLEY		2	2	2
⊙ 14	*302HS28170	2HS28170	GEAR FD Z29S		1	1	1
15	*5MVM273DB005	2A820100	PULLEY EXIT /A-49 FUSER A3		2	2	2
16	*5MVX111DN007	2BT11070	STOPPER 3 /2BT1107 A4		1	1	1
⊙ 17	302HS94160	2HS94160	COVER REAR ASSY SP		1	1	1
18	302HS28070	2HS28070	PULLEY EXIT		2	2	2
19	302HS28120	2HS28120	SPRING EXIT		2	2	2
20	302HS08320	2HS08320	SPRING COVER MPF		2	2	2
21	302F908200	2F908200	LOCK COVER		2	2	2

Ref. No.	Part.No.	Alternative.	Description	Notes	Quantity		
					120	230	240
101	7BB200410H	BB105700	+BIND T.T P SCREW 4X10				

- Parts with "⊙" indicate regular maintenance parts.
- Parts with Ref.No. indicate maintenance parts and the ones without it indicate out of the above.

- Parts with "\*" are component parts or sub-assemblies of the assembly appearing immediately above them.
- Parts with "•" are component parts or sub-assembly with "\*" appearing immediately above them.

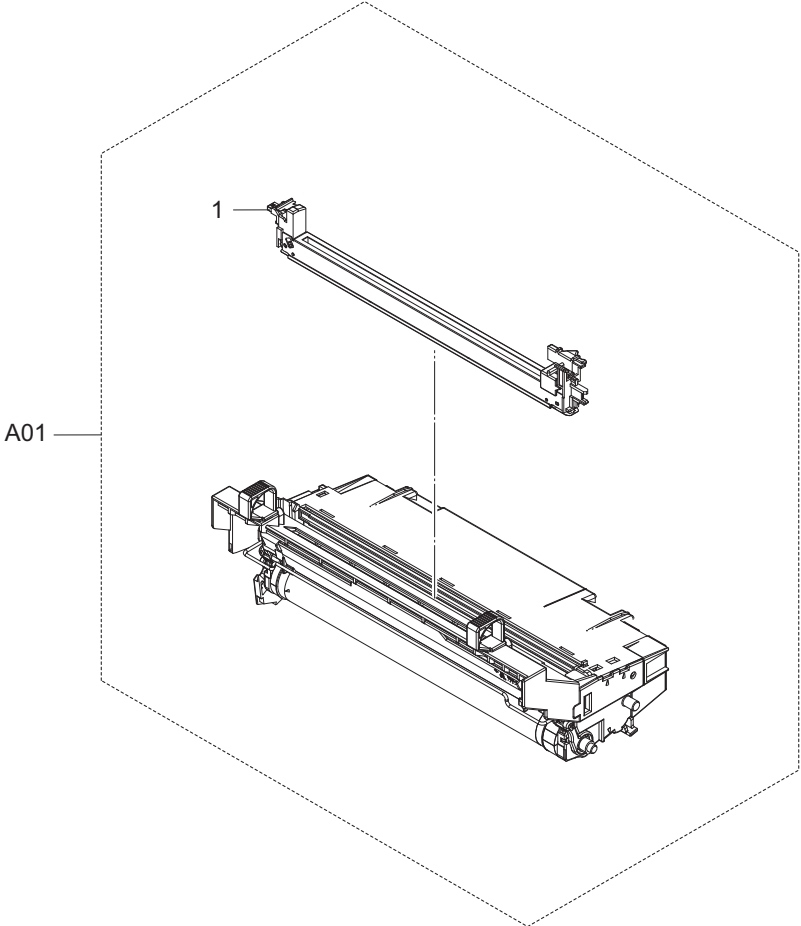
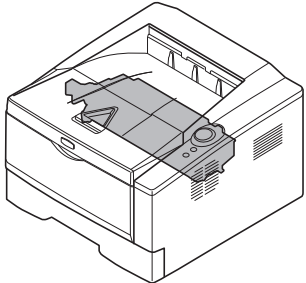

FIG. 6 Image Formation Section

2LY/2LZ/2PG/2PH-1

	Ref. No.	Part.No.	Alternative.	Description	Notes	Quantity		
						120	230	240
⊙	A01	302H493011	2H493011	DK-150	1120D	1	1	1
⊙	A01	302LZ93061	2LZ93061	DK-170	1320D, P2035d, P2135d	1	1	1
⊙	1	*302HS93070	2HS93070	MC-130		1	1	1

- Parts with "⊙" indicate regular maintenance parts.
- Parts with Ref.No. indicate maintenance parts and the ones without it indicate out of the above.

- Parts with "\*" are component parts or sub-assemblies of the assembly appearing immediately above them.
- Parts with "\*•" are component parts or sub-assembly with "\*•" appearing immediately above them.

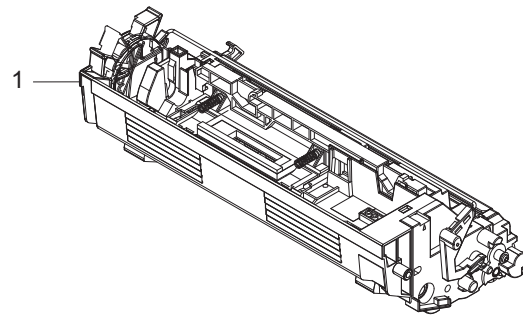
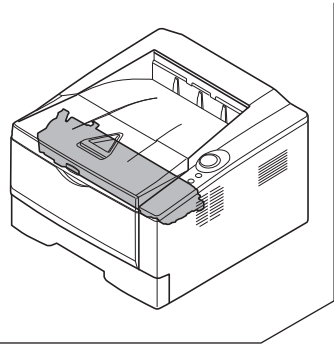

FIG. 7 Developing Section

2LY/2LZ/2PG/2PH-1

	Ref. No.	Part.No.	Alternative.	Description	Notes	Quantity		
						120	230	240
⊙	1	302LY93010	2LY93010	DV-160(E)	1120D, P2035d		1	
⊙	1	302LY93020	2LY93020	DV-162(U)	1120D, P2035d	1		
⊙	1	302LY93040	2LY93040	DV-164(AO)	1120D, P2035d			1
⊙	1	302LZ93010	2LZ93010	DV-170(E)	1320D, P2135d		1	
⊙	1	302LZ93020	2LZ93020	DV-172(U)	1320D, P2135d	1		
⊙	1	302LZ93080	2LZ93080	DV-174(AO)	1320D, P2135d			1

- Parts with "⊙" indicate regular maintenance parts.
- Parts with Ref.No. indicate maintenance parts and the ones without it indicate out of the above.

- Parts with "\*" are component parts or sub-assemblies of the assembly appearing immediately above them.
- Parts with "••" are component parts or sub-assembly with "•" appearing immediately above them.



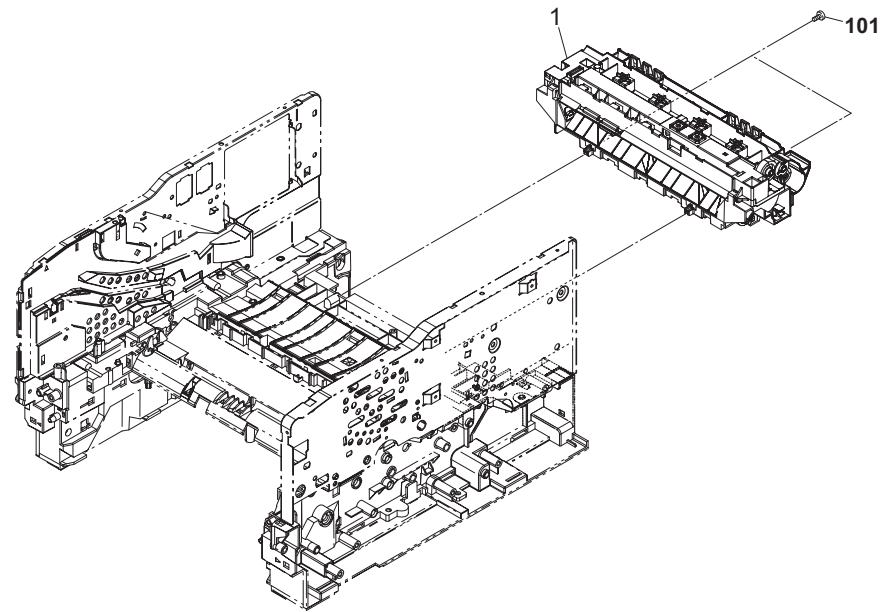
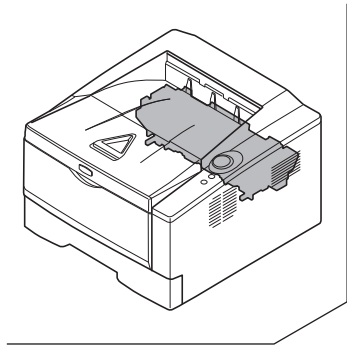

FIG. 8 Fuser Section

2LY/2LZ/2PG/2PH-1

	Ref. No.	Part.No.	Alternative.	Description	Notes	Quantity		
						120	230	240
⊙	1	302LZ93040	2LZ93040	FK-170(E)	1120D, 1320D	1	1	
⊙	1	302PH93010	2PH93010	FK-171(E)	P2035d, P2135d	1	1	
⊙	1	302LZ93050	2LZ93050	FK-170(U)	1120D, 1320D	1		
⊙	1	302PH93020	2PH93020	FK-171(U)	P2035d, P2135d	1		

	Ref. No.	Part.No.	Alternative.	Description	Notes	Quantity		
						120	230	240
	101	7BB200410H	BB105700	+BIND T.T P SCREW 4X10				

- Parts with "⊙" indicate regular maintenance parts.
- Parts with Ref.No. indicate maintenance parts and the ones without it indicate out of the above.

- Parts with "\*" are component parts or sub-assemblies of the assembly appearing immediately above them.
- Parts with "••" are component parts or sub-assembly with "•" appearing immediately above them.

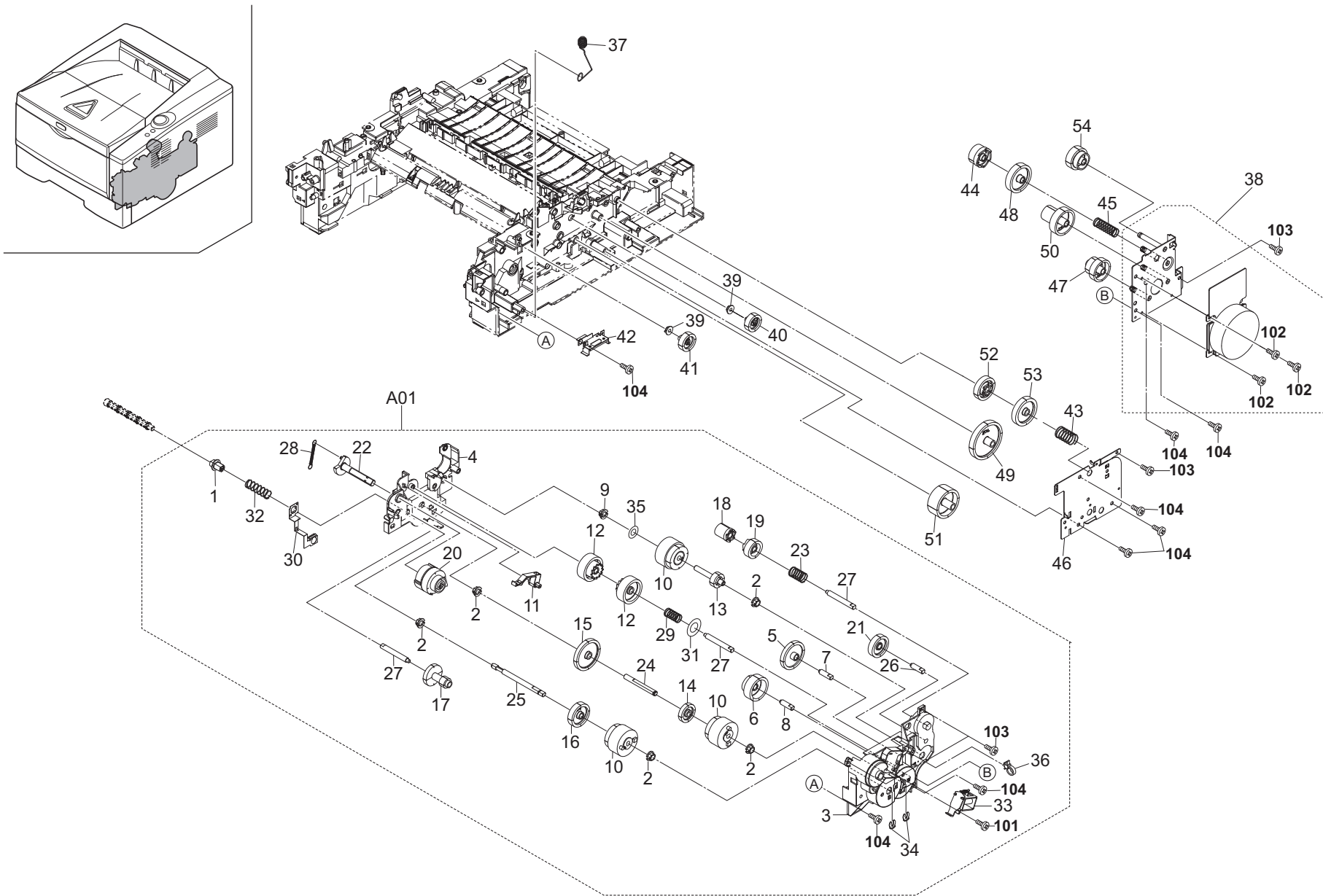

FIG. 9 Drive Section

2LY/2LZ/2PG/2PH-1

Ref. No.	Part.No.	Alternative.	Description	Notes	Quantity		
					120	230	240
⊙ A01	302H493040	2H493040	DR-150		1	1	1
1	*302F931350	2F931350	JOINT SHAFT CASSETTE		1	1	1
2	*302F931490	2F931490	BUSH FEED DRIVE		5	5	5
3	*302H431010	2H431010	HOLDER DRIVE		1	1	1
4	*302H431020	2H431020	COVER HOLDER DRIVE		1	1	1
⊙ 5	*302H431030	2H431030	GEAR Z42R		1	1	1
⊙ 6	*302H431040	2H431040	GEAR Z34L-Z24L		1	1	1
7	*302H431050	2H431050	PIN HOLDER A		1	1	1
8	*302H431060	2H431060	PIN HOLDER B		1	1	1
9	*302H431070	2H431070	BUSH DRIVE 6		1	1	1
⊙ 10	*302HN44111	2HN44111	CLUTCH FEED		3	3	3
11	*302HS31050	2HS31050	LEVER LIFT BOTTOM		1	1	1
⊙ 12	*302HS31090	2HS31090	GEAR Z37L FREE		2	2	2
⊙ 13	*302HS31100	2HS31100	GEAR Z20L CLUTCH		1	1	1
⊙ 14	*302HS31120	2HS31120	GEAR Z27L CLUTCH		1	1	1
⊙ 15	*302HS31130	2HS31130	GEAR Z45R CLUTCH		1	1	1
⊙ 16	*302HS31140	2HS31140	GEAR Z35R IDLE		1	1	1
⊙ 17	*302HS31150	2HS31150	GEAR Z31L-Z14S		1	1	1
⊙ 18	*302HS31190	2HS31190	GEAR Z17R FREE		1	1	1
⊙ 19	*302HS31200	2HS31200	GEAR Z26L FREE		1	1	1
⊙ 20	*302HS31230	2HS31230	GEAR Z38S MPF		1	1	1
⊙ 21	*302HS31260	2HS31260	GEAR Z32R		1	1	1
22	*302HS31281	2HS31281	LIFT BOTTOM		1	1	1
23	*302HS31320	2HS31320	SPRING FREE MAG		1	1	1
24	*302HS31330	2HS31330	PIN CLUTCH		1	1	1
25	*302HS31340	2HS31340	SHAFT CASSETTE		1	1	1
26	*302HS31360	2HS31360	PIN HOLDER A		1	1	1
27	*302HS31370	2HS31370	PIN HOLDER B		3	3	3
28	*302HS31380	2HS31380	SPRING LIFT BOTTOM		1	1	1
29	*302HS31410	2HS31410	SPRING FREE Z37L		1	1	1
30	*302HS31420	2HS31420	EARTH PLATE DRIVE		1	1	1
31	*302HS31430	2HS31430	POLYSLIDER 9.5		1	1	1
32	*302HS31440	2HS31440	SPRING FEED		1	1	1
⊙ 33	*302HS44020	2HS44020	SOLENOID MPF		1	1	1
⊙ 34	*5MVX111DN003	2A806250	RING STOPPER /A-49 FEED A4		2	2	2
35	*7BC06062C020H01	BC045240	POLY SLIDER WASHER M6.2X12X0.2T		1	1	1
36	*M2107250	M2107250	BAND,RSG-100(KITAGAWA)		1	1	1
37	302HS02370	2HS02370	SPRING EARTH CASSETTE		1	1	1
⊙ 38	302LZ94022	2LZ94022	PARTS MOTOR ASSY SP		1	1	1
39	302F929140	2F929140	BUSH DU		2	2	2
⊙ 40	302HS24220	2HS24220	GEAR Z25R DU FEED		1	1	1
⊙ 41	302HS24230	2HS24230	GEAR Z26L DU MID		1	1	1
42	302HS02381	2HS02381	PLATE PF CONNECTOR		1	1	1
43	302HS31310	2HS31310	SPRING FREE FUSER		1	1	1
⊙ 44	302HS31390	2HS31390	GEAR Z27R FREE 2		1	1	1
45	302LZ31040	2LZ31040	SPRING FREE DRUM		1	1	1
46	302HS31041	2HS31041	PLATE GEAR DRIVE		1	1	1
⊙ 47	302HS31250	2HS31250	GEAR Z54R-Z24R		1	1	1
⊙ 48	302HS31070	2HS31070	GEAR Z42R FREE 2		1	1	1

Ref. No.	Part.No.	Alternative.	Description	Notes	Quantity		
					120	230	240
⊙ 49	302HS31110	2HS31110	GEAR Z58L		1	1	1
⊙ 50	302H431080	2H431080	GEAR Z64R-Z21L		1	1	1
⊙ 51	302HS31180	2HS31180	GEAR Z44R		1	1	1
⊙ 52	302HS31210	2HS31210	GEAR Z35S FREE		1	1	1
⊙ 53	302HS31220	2HS31220	GEAR Z42R FREE		1	1	1
⊙ 54	302HS31240	2HS31240	GEAR Z32L DRUM		1	1	1
101	7BB200308H	BB105660	+BIND T.T P SCREW 3X8				
102	BAB53060	BAB53060	+TP TAP-TITE S SCREW M3X06				
103	7BB100306H	BB046010	+BIND T.T S SCREW 3X6				
104	7BB200410H	BB105700	+BIND T.T P SCREW 4X10				

- Parts with "⊙" indicate regular maintenance parts.
- Parts with Ref.No. indicate maintenance parts and the ones without it indicate out of the above.

- Parts with "\*" are component parts or sub-assemblies of the assembly appearing immediately above them.
- Parts with "• •" are component parts or sub-assembly with "•" appearing immediately above them.

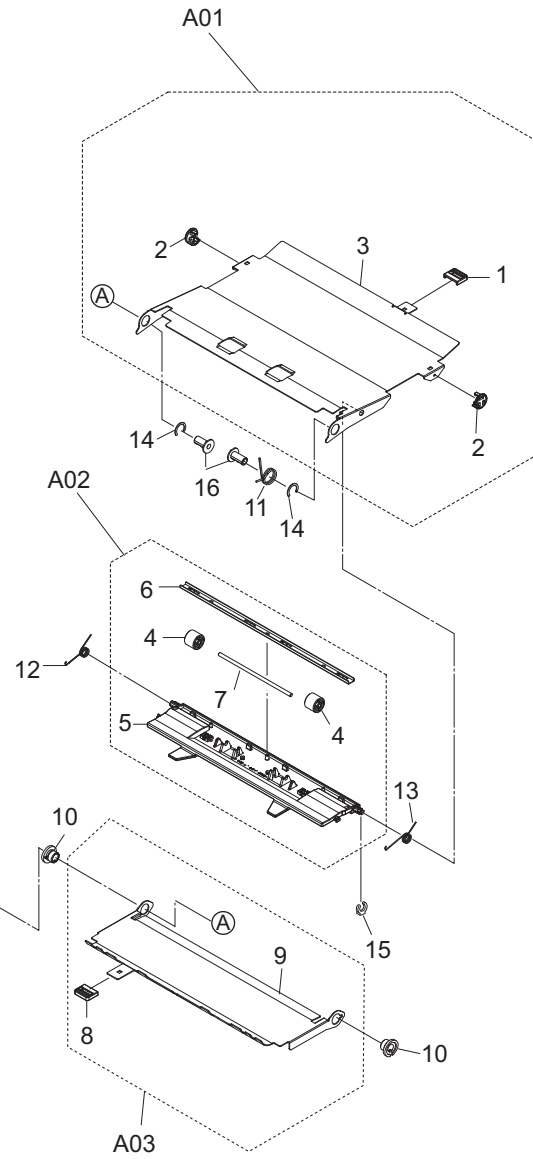
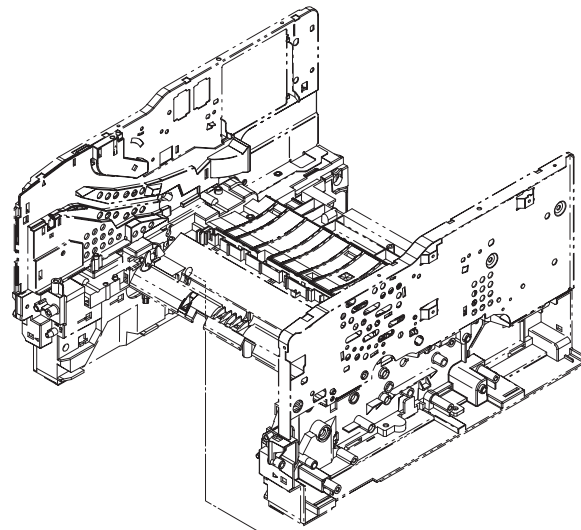
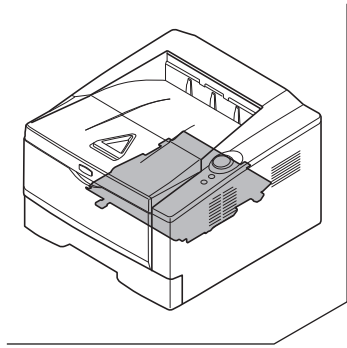

FIG. 10 Duplex Section

2LY/2LZ/2PG/2PH-1

Ref. No.	Part.No.	Alternative.	Description	Notes	Quantity		
					120	230	240
⊙ A01	302HS94320	2HS94320	PARTS PLATE COVER DU B ASSY SP		1	1	1
1	*2FM02690	5MVX221DG002	LEVER DU /B-11 DU A3		1	1	1
2	*2FM21050	5MVX173DN001	COLLER DU /B-11 DU A3		2	2	2
3	*302HS29020	2HS29020	PLATE COVER DU B		1	1	1
⊙ A02	302FM94061	2FM94061	PARTS HOLDER DU ASSY SP		1	1	1
⊙ 4	*2FM02210	5MVM274DN002	PULLEY MID /B-11 FRAME A4		2	2	2
5	*302FM21011	2FM21011	HOLDER DU		1	1	1
6	*2FM21020	5MML821SD009	STAY DU /B-11 DU A3		1	1	1
7	*302FM02421	2FM02421	SHAFT PULLEY /B-11 FRAME A4		1	1	1
⊙ A03	302HS94331	2HS94331	PARTS PLATE COVER DU ASSY SP		1	1	1
8	*2FM02690	5MVX221DG002	LEVER DU /B-11 DU A3		1	1	1
9	*302HS29011	2HS29011	PLATE COVER DU		1	1	1
10	2FM02140	5MVM786XB001	BUSH DU /B-11 FRAME A3		2	2	2
11	2FM02500	5MMW176SD002	SPRING DU R /B-11 FRAME A4		1	1	1
12	2FM02510	5MMW166SD002	SPRING HOLDER L /B-11 FRAME A4		1	1	1
13	2FM02520	5MMW166SD003	SPRING HOLDER R /B-11 FRAME A4		1	1	1
14	5MBCK9560XSC	D4103700	C STOP RING /X9.5 X 0.6T S-CR		2	2	2
⊙ 15	5MVX111DN003	2A806250	RING STOPPER /A-49 FEED A4		1	1	1
16	2FM21030	5MVM276DN017	STOPPER BUSH /B-11 DU A4		2	2	2

- Parts with "⊙" indicate regular maintenance parts.
- Parts with Ref.No. indicate maintenance parts and the ones without it indicate out of the above.

- Parts with "\*" are component parts or sub-assemblies of the assembly appearing immediately above them.
- Parts with "••" are component parts or sub-assembly with "•" appearing immediately above them.

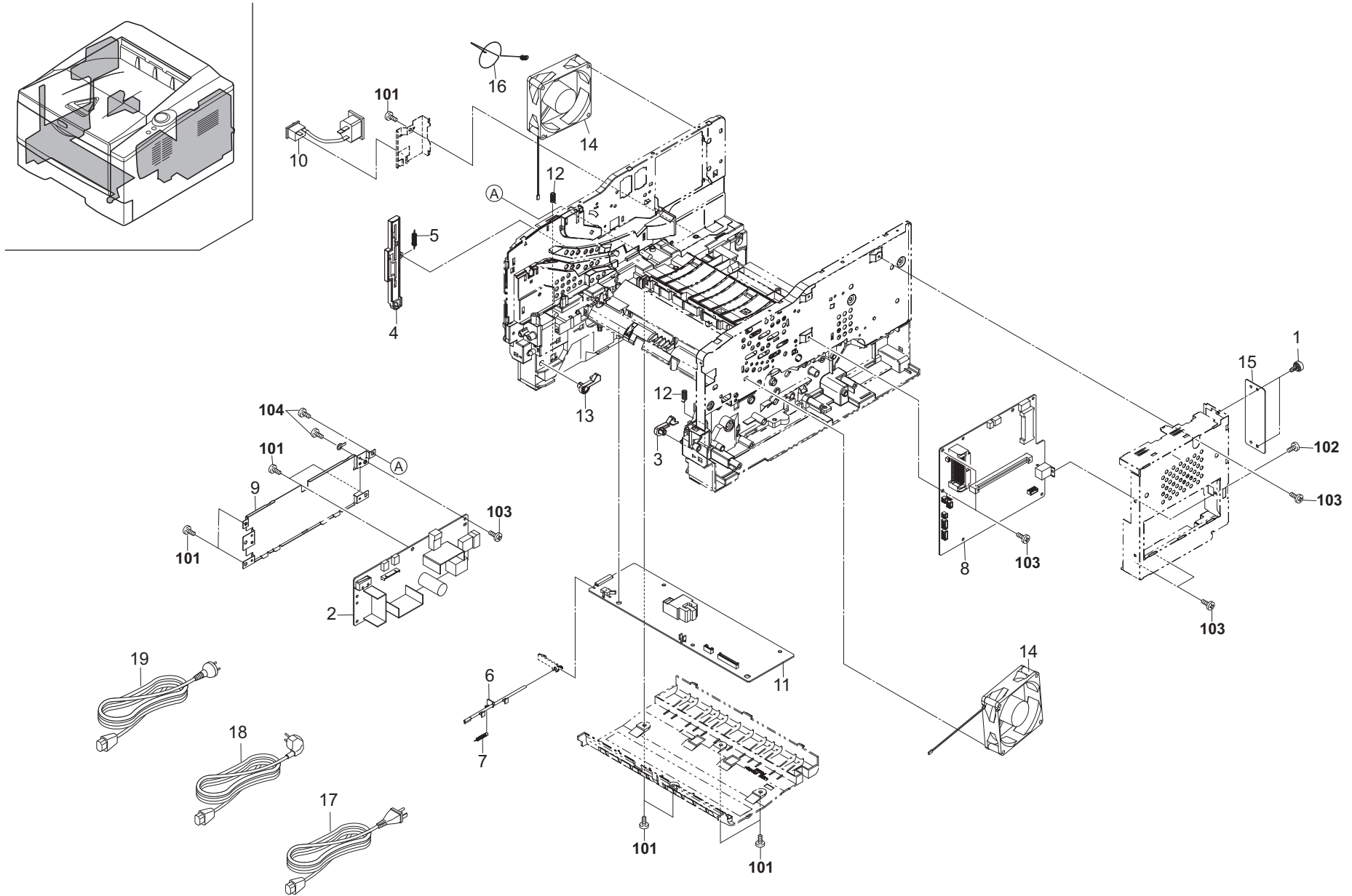

FIG. 11 Electrical Components

2LY/2LZ/2PG/2PH-1

Ref. No.	Part.No.	Alternative.	Description	Notes	Quantity		
					120	230	240
1	302F939082	2F939082	SCREW BOX		2	2	2
⊙ 2	302HS45013	2HS45013	SWITCHING REGULATOR 230V				1
⊙ 2	302LZ94170	2LZ94170	PARTS SWITCHING REGULATOR 230V SP	1120D, 1320D		1	
⊙ 2	302PG94020	2PG94020	PARTS SWITCHING REGULATOR 230V SP	P2035d, P2135d		1	
⊙ 2	302HS45021	2HS45021	SWITCHING REGULATOR 120V		1		
⊙ 3	302HS02070	2HS02070	LEVER LOCK CASSETTE		1	1	1
⊙ 4	302HS02110	2HS02110	LEVER INTERLOCK SW		1	1	1
⊙ 5	302HS02120	2HS02120	SPRING INTERLOCK SW		1	1	1
⊙ 6	302HS02180	2HS02180	PIN CASSETTE		1	1	1
⊙ 7	302HS02190	2HS02190	SPRING PIN CASSETTE		1	1	1
⊙ 8	302LY94010	2LY94010	PARTS PWB CONTROL SP	1120D	1		1
⊙ 8	302LY94040	2LY94040	PARTS PWB ASSY CONTROL SP	1120D		1	
⊙ 8	302LZ94080	2LZ94080	PARTS PWB CONTROL SP	1320D	1		1
⊙ 8	302LZ94160	2LZ94160	PARTS PWB ASSY CONTROL SP	1320D		1	
⊙ 8	302PG94030	2PG94030	PARTS PWB ASSY MAIN SP	P2035d	1		1
⊙ 8	302PG94040	2PG94040	PARTS PWB ASSY MAIN EU SP	P2035d		1	
⊙ 8	302PH94020	2PH94020	PARTS PWB ASSY MAIN SP	P2135d	1		1
⊙ 8	302PH94030	2PH94030	PARTS PWB ASSY MAIN EU SP	P2135d		1	
⊙ 9	302HS02210	2HS02210	PLATE POWER SUPPLY		1	1	1
10	302HS46120	2HS46120	CONN.CORD ASSY PWS-INLET S03238		1		1
10	302LZ46030	2LZ46030	CONN.CORD ASSY S03808			1	
⊙ 11	302H494220	2H494220	PARTS HIGH VOLTAGE UNIT SP	1120D	1	1	1
⊙ 11	302LZ94041	2LZ94041	PARTS HIGH VOLTAGE UNIT SP	1320D, P2035d, P2135d	1	1	1
⊙ 12	302HS02360	2HS02360	SPRING LOCK CASSETTE		2	2	2
⊙ 13	302HS02390	2HS02390	LEVER LOCK CASSETTE L		1	1	1
⊙ 14	302LZ94030	2LZ94030	PARTS MOTOR FAN 80 SP		2	2	2
15	302HS39040	2HS39040	PLATE OPTION		1	1	1
16	302HS02620	2HS02620	SPRING EARTH FAN		1	1	1
17	7AAACCUS+10H001	AA068380	AC CORD ASSY US		1		
18	302FV94010	2FV94010	PARTS AC CORD EU SP			1	
19	302FV45040	2FV45040	AC CORD ASSY				1

Ref. No.	Part.No.	Alternative.	Description	Notes	Quantity		
					120	230	240
101	7BB200410H	BB105700	+BIND T.T P SCREW 4X10				
102	5MBSPB3006NW++R	B1B03060	BIND HEAD SCREW(+)/ M3 X 6 CRFREE				
103	7BB100306H1	BB105820	+BIND T.T S SCREW 3X6				
104	5MBTPB4006TW++R	B1A54060	BIND T.T SCREW(+)/ M4 X 6 CRFREE S-T				

- Parts with "⊙" indicate regular maintenance parts.
- Parts with Ref.No. indicate maintenance parts and the ones without it indicate out of the above.

- Parts with "\*" are component parts or sub-assemblies of the assembly appearing immediately above them.
- Parts with "••" are component parts or sub-assembly with "•" appearing immediately above them.



FIG. 12 Maintenance Kits

2LY/2LZ/2PG/2PH-1

Ref. No.	Part.No.	Alternative.	Description	Notes	Quantity		
					120	230	240
	1702LY7US0	072LY7US	MK-162/MAINTENANCE KIT	OPTION 1120D	1		
			DK-150		1		
			DV-162(U)		1		
	1702LY8AS0	072LY8AS	MK-164/MAINTENANCE KIT	OPTION 1120D			1
			DK-150				1
			DV-164(AO)				1
	1702LY8NL0	072LY8NL	MK-160/MAINTENANCE KIT	OPTION 1120D	1		
			DK-150		1		
			DV-160(E)		1		
	1702LZ7US0	072LZ7US	MK-172/MAINTENANCE KIT	OPTION 1320D, P2135d	1		
			DV-172(U)		1		
			DK-170		1		
	1702LZ8AS0	072LZ8AS	MK-174/MAINTENANCE KIT	OPTION 1320D, P2135d			1
			DV-174(AO)				1
			DK-170				1
	1702LZ8NL0	072LZ8NL	MK-170/MAINTENANCE KIT	OPTION 1320D, P2135d	1		
			DV-170(E)		1		
			DK-170		1		
	1702PG7US0	072PG7US	MK-182/MAINTENANCE KIT	OPTION P2035d	1		
			DV-162(U)		1		
			DK-170		1		
	1702PG8AS0	072PG8AS	MK-184/MAINTENANCE KIT	OPTION P2035d			1
			DV-164(AO)				1
			DK-170				1
	1702PG8NL0	072PG8NL	MK-180/MAINTENANCE KIT	OPTION P2035d	1		
			DV-160(E)		1		
			DK-170		1		

- Parts with "⊙" indicate regular maintenance parts.
- Parts with Ref.No. indicate maintenance parts and the ones without it indicate out of the above.

- Parts with "\*" are component parts or sub-assemblies of the assembly appearing immediately above them.
- Parts with "••" are component parts or sub-assembly with "•" appearing immediately above them.

INDEX

2LY/2LZ/2PG/2PH-1

Part.No.	Alternative.	Description	Fig.No.
1702LY7US0	072LY7US	MK-162/MAINTENANCE KIT	12
1702LY8AS0	072LY8AS	MK-164/MAINTENANCE KIT	12
1702LY8NL0	072LY8NL	MK-160/MAINTENANCE KIT	12
1702LZ7US0	072LZ7US	MK-172/MAINTENANCE KIT	12
1702LZ8AS0	072LZ8AS	MK-174/MAINTENANCE KIT	12
1702LZ8NL0	072LZ8NL	MK-170/MAINTENANCE KIT	12
1702PG7US0	072PG7US	MK-182/MAINTENANCE KIT	12
1702PG8AS0	072PG8AS	MK-184/MAINTENANCE KIT	12
1702PG8NL0	072PG8NL	MK-180/MAINTENANCE KIT	12
⊙ 2BL06380	2BL06380	GEAR Z25 JOINT	5
2FM02140	5MVM786XB001	BUSH DU /B-11 FRAME A3	10
⊙ 2FM02210	5MVM274DN002	PULLEY MID /B-11 FRAME A4	10
⊙ 2FM02350	5MVG133DN022	GEAR Z22 /B-11 FRAME A4	5
2FM02500	5MMW176SD002	SPRING DU R /B-11 FRAME A4	10
2FM02510	5MMW166SD002	SPRING HOLDER L /B-11 FRAME A4	10
2FM02520	5MMW166SD003	SPRING HOLDER R /B-11 FRAME A4	10
2FM02690	5MVX221DG002	LEVER DU /B-11 DU A3	10
2FM06010	5MVX765SH004	GUIDE SIDE L /B-11 CASSETTE A2	3
2FM06020	5MVX765SH005	GUIDE SIDE R /B-11 CASSETTE A2	3
2FM21020	5MML821SD009	STAY DU /B-11 DU A3	10
2FM21030	5MVM276DN017	STOPPER BUSH /B-11 DU A4	10
2FM21050	5MVX173DN001	COLLER DU /B-11 DU A3	10
⊙ 302A816031	2A816031	BUSH TC R /A-49 FEED A4	4
⊙ 302BR06521	2BR06521	RETARD ROLL ASSY /43487V0005 A4	3
302F902420	2F902420	LOCK COVER TOP R	2
302F904120	2F904120	EMBLEM KYOCERA	1
302F904130	2F904130	TAPE EMBLEM	1
302F906170	2F906170	JOINT PICKUP A	4
302F906180	2F906180	JOINT PICKUP B	4
302F906230	2F906230	PULLEY FEED ASSY	4
302F906240	2F906240	PULLEY PICKUP ASSY	4
302F906272	2F906272	SHAFT FEED L	4
302F906280	2F906280	GEAR FEED Z30H	4
302F908200	2F908200	LOCK COVER	2,5
302F908270	2F908270	SP BOTTOM MPF L	2
302F908310	2F908310	PAD FRICTION MPF	2
302F909031	2F909031	LEVER BASE CAS REAR	3
302F909040	2F909040	SPRING BASE CAS REAR	3
302F909210	2F909210	PAD BOTTOM	3
302F929140	2F929140	BUSH DU	5,9
302F931270	2F931270	SPRING FUSER	1
302F931350	2F931350	JOINT SHAFT CASSETTE	9
302F931490	2F931490	BUSH FEED DRIVE	9
302F939082	2F939082	SCREW BOX	11
302FM02421	2FM02421	SHAFT PULLEY /B-11 FRAME A4	10
302FM21011	2FM21011	HOLDER DU	10
⊙ 302FM94020	2FM94020	GEAR CLUTCH ASSY A SP	5
⊙ 302FM94030	2FM94030	GEAR CLUTCH ASSY B SP	5
⊙ 302FM94061	2FM94061	PARTS HOLDER DU ASSY SP	10
302FV45040	2FV45040	AC CORD ASSY	11

Part.No.	Alternative.	Description	Fig.No.
302FV94010	2FV94010	PARTS AC CORD EU SP	11
302H402040	2H402040	SPRING REG GND	2
302H402050	2H402050	BUSH REGIST	4
302H402060	2H402060	SPRING EARTH DU FEED	2
⊙ 302H428020	2H428020	DISCHARGER FD	5
302H431010	2H431010	HOLDER DRIVE	9
302H431020	2H431020	COVER HOLDER DRIVE	9
⊙ 302H431030	2H431030	GEAR Z42R	9
⊙ 302H431040	2H431040	GEAR Z34L-Z24L	9
302H431050	2H431050	PIN HOLDER A	9
302H431060	2H431060	PIN HOLDER B	9
302H431070	2H431070	BUSH DRIVE 6	9
⊙ 302H431080	2H431080	GEAR Z64R-Z21L	9
⊙ 302H493011	2H493011	DK-150	6
⊙ 302H493040	2H493040	DR-150	9
⊙ 302H494020	2H494020	ERASER KIT (N) SP	2
⊙ 302H494070	2H494070	SOLENOID ASSY SP	5
⊙ 302H494080	2H494080	HOLDER DC BRUSH ASSY	4
⊙ 302H494220	2H494220	PARTS HIGH VOLTAGE UNIT SP	11
⊙ 302H994360	2H994360	PARTS FULL SENSOR ASSY SP	2
302HN09190	2HN09190	SPRING FIX	3
302HN29050	2HN29050	BUSH DU	5
⊙ 302HN44111	2HN44111	CLUTCH FEED	9
⊙ 302HS01030	2HS01030	P.W.B BOARD ASSY PANEL	1
302HS01130	2HS01130	P.W.B RFID WITH SOFTWARE	4
⊙ 302HS02070	2HS02070	LEVER LOCK CASSETTE	11
⊙ 302HS02090	2HS02090	LEVER STOPPER DLP	2
302HS02100	2HS02100	SPRING STOPPER DLP	2
⊙ 302HS02110	2HS02110	LEVER INTERLOCK SW	11
302HS02120	2HS02120	SPRING INTERLOCK SW	11
302HS02160	2HS02160	SPRING MC	2
⊙ 302HS02180	2HS02180	PIN CASSETTE	11
⊙ 302HS02190	2HS02190	SPRING PIN CASSETTE	11
⊙ 302HS02210	2HS02210	PLATE POWER SUPPLY	11
302HS02260	2HS02260	SPRING EARTH REG LOW	4
302HS02330	2HS02330	SPRING EARTH DU PLATE	2
302HS02340	2HS02340	SPRING EARTH RIGHT	4
302HS02360	2HS02360	SPRING LOCK CASSETTE	11
302HS02370	2HS02370	SPRING EARTH CASSETTE	9
302HS02381	2HS02381	PLATE PF CONNECTOR	9
⊙ 302HS02390	2HS02390	LEVER LOCK CASSETTE L	11
302HS02410	2HS02410	SPRING EARTH DU MID	4
302HS02440	2HS02440	SPRING EARTH DLP PLATE	4
302HS02461	2HS02461	PIN CONTACT BIAS	2
302HS02470	2HS02470	SPRING PIN BIAS	2
302HS02620	2HS02620	SPRING EARTH FAN	11
⊙ 302HS02650	2HS02650	HOOK PF	2
⊙ 302HS04070	2HS04070	COVER RACK	1
302HS04080	2HS04080	COVER PANEL	1
302HS04100	2HS04100	BUTTON ENTER	1

• Parts with "⊙" indicate regular maintenance parts.

	Part.No.	Alternative.	Description	Fig.No.
⊙	302HS04110	2HS04110	BUTTON CANCEL	1
	302HS04160	2HS04160	COVER RACK B	1
	302HS04170	2HS04170	SHEET TOP COVER	1
	302HS06010	2HS06010	FRAME FEED	4
	302HS06020	2HS06020	HOLDER FEED	4
	302HS06050	2HS06050	PULLEY FEED	4
⊙	302HS06071	2HS06071	ACTUATOR EMPTY B	4
⊙	302HS06090	2HS06090	GEAR Z22S FEED	4
	302HS06120	2HS06120	SPRING ACTUATOR	4
	302HS06130	2HS06130	SPRING PULLEY	4
	302HS08011	2HS08011	FRAME MPF	4
	302HS08050	2HS08050	BASE MPF	2
	302HS08080	2HS08080	SHAFT FEED MPF	4
	302HS08100	2HS08100	BRACKET BOTTOM	2
⊙	302HS08110	2HS08110	ACTUATOR MPF	4
⊙	302HS08160	2HS08160	GEAR Z20S MPF	4
	302HS08170	2HS08170	SPRING SEPARATOR	2
	302HS08190	2HS08190	SPRING ACTUATOR	4
	302HS08210	2HS08210	SPRING EARTH MPF	2
	302HS08230	2HS08230	PLATE EARTH BOTTOM	2
	302HS08241	2HS08241	GUIDE MPF R	2
	302HS08251	2HS08251	GUIDE MPF L	2
⊙	302HS08260	2HS08260	ROLLER M/P ASSY	4
	302HS08270	2HS08270	SPRING BRACKET	2
	302HS08320	2HS08320	SPRING COVER MPF	2,5
	302HS09070	2HS09070	PAPER INDICATOR	3
	302HS09081	2HS09081	CURSOR END	3
	302HS09100	2HS09100	LOCK BOTTOM	3
	302HS09120	2HS09120	SPRING BOTTOM L	3
	302HS09130	2HS09130	SPRING BOTTOM R	3
	302HS09140	2HS09140	SPRING LOCK BOTTOM	3
	302HS09160	2HS09160	GEAR CASSETTE	3
	302HS09180	2HS09180	SPRING RETARD	3
	302HS09260	2HS09260	HOLDER RETARD	3
	302HS24070	2HS24070	SPRING ACTUATOR REG	2
	302HS24120	2HS24120	BUSH REGIST	4
	302HS24130	2HS24130	BUSH 4 DU ROLL	2
	302HS24140	2HS24140	BUSH 6 EW	4
⊙	302HS24160	2HS24160	ROLLER DU	2
	302HS24181	2HS24181	SHEET REGIST	4
⊙	302HS24190	2HS24190	GEAR Z14R REG UP	4
⊙	302HS24200	2HS24200	GEAR Z21L-Z23L REG LOW	4
⊙	302HS24220	2HS24220	GEAR Z25R DU FEED	9
⊙	302HS24230	2HS24230	GEAR Z26L DU MID	9
⊙	302HS24250	2HS24250	BUSH TC R	4
	302HS24280	2HS24280	SPRING RELEASE TC L	4
	302HS24300	2HS24300	SPRING CONTACT TC	2
	302HS24310	2HS24310	SPRING EARTH BRUSH	4
	302HS24360	2HS24360	SPRING REGIST C	4
	302HS24400	2HS24400	SPRING TC R	4

	Part.No.	Alternative.	Description	Fig.No.
	302HS24410	2HS24410	ROLLER REGIST LOW	4
	302HS24460	2HS24460	BUSH REGIST R	4
	302HS28041	2HS28041	COVER FD	5
⊙	302HS28060	2HS28060	GEAR Z21S	5
	302HS28070	2HS28070	PULLEY EXIT	5
	302HS28110	2HS28110	SPRING EARTH	5
	302HS28120	2HS28120	SPRING EXIT	5
	302HS28141	2HS28141	SPRING PULLEY	5
⊙	302HS28170	2HS28170	GEAR FD Z29S	5
⊙	302HS28830	2HS28830	ROLLER FD UP B	5
	302HS29011	2HS29011	PLATE COVER DU	10
	302HS29020	2HS29020	PLATE COVER DU B	10
	302HS31041	2HS31041	PLATE GEAR DRIVE	9
	302HS31050	2HS31050	LEVER LIFT BOTTOM	9
⊙	302HS31070	2HS31070	GEAR Z42R FREE 2	9
⊙	302HS31090	2HS31090	GEAR Z37L FREE	9
⊙	302HS31100	2HS31100	GEAR Z20L CLUTCH	9
⊙	302HS31110	2HS31110	GEAR Z58L	9
⊙	302HS31120	2HS31120	GEAR Z27L CLUTCH	9
⊙	302HS31130	2HS31130	GEAR Z45R CLUTCH	9
⊙	302HS31140	2HS31140	GEAR Z35R IDLE	9
⊙	302HS31150	2HS31150	GEAR Z31L-Z14S	9
⊙	302HS31180	2HS31180	GEAR Z44R	9
⊙	302HS31190	2HS31190	GEAR Z17R FREE	9
⊙	302HS31200	2HS31200	GEAR Z26L FREE	9
⊙	302HS31210	2HS31210	GEAR Z35S FREE	9
⊙	302HS31220	2HS31220	GEAR Z42R FREE	9
⊙	302HS31230	2HS31230	GEAR Z38S MPF	9
⊙	302HS31240	2HS31240	GEAR Z32L DRUM	9
⊙	302HS31250	2HS31250	GEAR Z54R-Z24R	9
⊙	302HS31260	2HS31260	GEAR Z32R	9
	302HS31281	2HS31281	LIFT BOTTOM	9
	302HS31310	2HS31310	SPRING FREE FUSER	9
	302HS31320	2HS31320	SPRING FREE MAG	9
	302HS31330	2HS31330	PIN CLUTCH	9
	302HS31340	2HS31340	SHAFT CASSETTE	9
	302HS31360	2HS31360	PIN HOLDER A	9
	302HS31370	2HS31370	PIN HOLDER B	9
	302HS31380	2HS31380	SPRING LIFT BOTTOM	9
⊙	302HS31390	2HS31390	GEAR Z27R FREE 2	9
	302HS31410	2HS31410	SPRING FREE Z37L	9
	302HS31420	2HS31420	EARTH PLATE DRIVE	9
	302HS31430	2HS31430	POLYSLIDER 9.5	9
	302HS31440	2HS31440	SPRING FEED	9
	302HS34080	2HS34080	LABEL JAM TK OPERATION	1
	302HS39040	2HS39040	PLATE OPTION	11
⊙	302HS44020	2HS44020	SOLENOID MPF	9
⊙	302HS45013	2HS45013	SWITCHING REGULATOR 230V	11
⊙	302HS45021	2HS45021	SWITCHING REGULATOR 120V	11
	302HS46120	2HS46120	CONN.CORD ASSY PWS-INLET S03238	11

• Parts with "⊙" indicate regular maintenance parts.

	Part.No.	Alternative.	Description	Fig.No.		Part.No.	Alternative.	Description	Fig.No.
	302HS46230	2HS46230	CONN.CORD ASSY PANEL-RELAY S03353	1		302LZ93030	2LZ93030	LK-170	2
⊙	302HS93070	2HS93070	MC-130	6	⊙	302LZ93040	2LZ93040	FK-170(E)	8
⊙	302HS94000	2HS94000	PLATE BOTTOM ASSY	3	⊙	302LZ93050	2LZ93050	FK-170(U)	8
⊙	302HS94010	2HS94010	COVER TOP ASSY	1	⊙	302LZ93061	2LZ93061	DK-170	6
⊙	302HS94020	2HS94020	LID TOP ASSY	1	⊙	302LZ93071	2LZ93071	CT-170	3
⊙	302HS94032	2HS94032	HOLDER FEED ASSY	4	⊙	302LZ93080	2LZ93080	DV-174(AO)	7
⊙	302HS94040	2HS94040	SEPARATOR MPF ASSY	2	⊙	302LZ94010	2LZ94010	PARTS PWB ERASER SP	2
⊙	302HS94050	2HS94050	PLATE BOTTOM MPF ASSY	2	⊙	302LZ94022	2LZ94022	PARTS MOTOR ASSY SP	9
⊙	302HS94081	2HS94081	REGIST LOW KIT	4	⊙	302LZ94030	2LZ94030	PARTS MOTOR FAN 80 SP	11
⊙	302HS94121	2HS94121	COVER FRONT ASSY (2HS) SP	1	⊙	302LZ94041	2LZ94041	PARTS HIGH VOLTAGE UNIT SP	11
⊙	302HS94140	2HS94140	COVER TOP B KIT SP	1	⊙	302LZ94050	2LZ94050	PARTS ROLLER REGIST UP SP	4
⊙	302HS94150	2HS94150	EMPTY SENSOR KIT SP	4	⊙	302LZ94060	2LZ94060	PARTS ROLLER TRANSFER E SP	4
⊙	302HS94160	2HS94160	COVER REAR ASSY SP	5	⊙	302LZ94070	2LZ94070	PARTS ROLLER TRANSFER A SP	4
⊙	302HS94281	2HS94281	HOLDER MCH ASSY	2	⊙	302LZ94080	2LZ94080	PARTS PWB CONTROL SP	11
⊙	302HS94320	2HS94320	PARTS PLATE COVER DU B ASSY SP	10	⊙	302LZ94090	2LZ94090	PARTS TRAY MPF ASSY SP	2
⊙	302HS94331	2HS94331	PARTS PLATE COVER DU ASSY SP	10	⊙	302LZ94100	2LZ94100	PARTS FD ASSY (2LZ) SP	5
⊙	302J002010	2J002010	FOOT	2	⊙	302LZ94140	2LZ94140	PARTS COVER RIGHT 2 ASSY SP	1
⊙	302LY00010	2LY00010	COVER RIGHT ASSY	1	⊙	302LZ94160	2LZ94160	PARTS PWB ASSY CONTROL SP	11
	302LY04010	2LY04010	COVER RIGHT	1	⊙	302LZ94170	2LZ94170	PARTS SWITCHING REGULATOR 230V SP	11
	302LY04020	2LY04020	COVER RIGHT 2	1	⊙	302LZ94180	2LZ94180	PARTS PWB ASSY SWITCH SP	1
⊙	302LY93010	2LY93010	DV-160(E)	7	⊙	302PG00020	2PG00020	COVER RIGHT ASSY	1
⊙	302LY93020	2LY93020	DV-162(U)	7	⊙	302PG04020	2PG04020	COVER RIGHT	1
⊙	302LY93030	2LY93030	LK-160	2	⊙	302PG04030	2PG04030	COVER RIGHT 2	1
⊙	302LY93040	2LY93040	DV-164(AO)	7	⊙	302PG04070	2PG04070	BUTTON ENTER	1
⊙	302LY94010	2LY94010	PARTS PWB CONTROL SP	11	⊙	302PG94010	2PG94010	PARTS COVER RIGHT 2 ASSY SP	1
⊙	302LY94030	2LY94030	PARTS COVER RIGHT 2 ASSY SP	1	⊙	302PG94020	2PG94020	PARTS SWITCHING REGULATOR 230V SP	11
⊙	302LY94040	2LY94040	PARTS PWB ASSY CONTROL SP	11	⊙	302PG94030	2PG94030	PARTS PWB ASSY MAIN SP	11
⊙	302LZ00010	2LZ00010	COVER RIGHT ASSY	1	⊙	302PG94040	2PG94040	PARTS PWB ASSY MAIN EU SP	11
	302LZ02100	2LZ02100	SPRING EARTH REG UP	4	⊙	302PH00020	2PH00020	COVER RIGHT ASSY	1
⊙	302LZ04011	2LZ04011	COVER LEFT	1		302PH04010	2PH04010	COVER RIGHT	1
	302LZ04020	2LZ04020	COVER RIGHT	1		302PH04020	2PH04020	COVER RIGHT 2	1
	302LZ04030	2LZ04030	COVER DIMM	1	⊙	302PH93010	2PH93010	FK-171(E)	8
	302LZ04050	2LZ04050	MOUNT PWB SW	1	⊙	302PH93020	2PH93020	FK-171(U)	8
	302LZ04060	2LZ04060	KEY POWER	1	⊙	302PH94010	2PH94010	PARTS COVER RIGHT 2 ASSY SP	1
	302LZ04070	2LZ04070	HOLDER KEY SW	1	⊙	302PH94020	2PH94020	PARTS PWB ASSY MAIN SP	11
	302LZ04080	2LZ04080	COVER RIGHT 2	1	⊙	302PH94030	2PH94030	PARTS PWB ASSY MAIN EU SP	11
	302LZ04090	2LZ04090	COVER MAIN SW	1		5MBCK9560XSC	D4103700	C STOP RING /X9.5 X 0.6T S-CR	10
⊙	302LZ06011	2LZ06011	ACTUATOR EMPTY A	4		5MMW171LD006	2A807530	SPRING STOPPER /A49 CASSETTE A4	3
	302LZ08020	2LZ08020	GUIDE TURN MPF	2		5MMW261LD036	2A814570	SPRING TE SENSOR /A-49 DLP A4	4
	302LZ09030	2LZ09030	GUIDE RETARD	3		5MMW261LD067	2FV02270	SPRING LEVER LOCK L	4
⊙	302LZ24010	2LZ24010	GEAR Z17L TC	4		5MMW261LD068	2FV02280	SPRING LEVER LOCK R	4
	302LZ24030	2LZ24030	ACTUATOR REGIST	2		5MVG137DN032	2A806720	GEAR MPF /A-49 MPF A4	2
	302LZ24090	2LZ24090	SPRING TC L	4		5MVM273DB005	2A820100	PULLEY EXIT /A-49 FUSER A3	4,5
⊙	302LZ24110	2LZ24110	SPRING REGIST RB	4	⊙	5MVX111DN003	2A806250	RING STOPPER /A-49 FEED A4	4,9,10
⊙	302LZ24120	2LZ24120	SPRING REGIST LB	4		5MVX111DN007	2BT11070	STOPPER 3 /2BT1107 A4	5
	302LZ24220	2LZ24220	BUSH REGIST C	4	⊙	5MVX431DN005	2FV02100	LEVER LOCK DLP	4
	302LZ31040	2LZ31040	SPRING FREE DRUM	9		5MVX541DG002	2A807191	LEVER REAR /A-49 CASSETTE A3	3
	302LZ46030	2LZ46030	CONN.CORD ASSY S03808	11		5MVX541DG003	2A807161	LEVER SIDE /A-49 CASSETTE A3	3
⊙	302LZ93010	2LZ93010	DV-170(E)	7		7AAACCUS+10H001	AA068380	AC CORD ASSY US	11
⊙	302LZ93020	2LZ93020	DV-172(U)	7		7BC06062C020H01	BC045240	POLY SLIDER WASHER M6.2X12X0.2T	9

• Parts with "⊙" indicate regular maintenance parts.

	Part.No.	Alternative.	Description	Fig.No.
	7BC460529080H01 7NXSG2481+++H01 7RHA2H10701+H01 M2107250	BC059590 NX052600 RH043740 M2107250	CUT WASHER 5.2X9.0X0.8T(BLACK) SENSOR OPT. M.GLAZE R. 100MJ 1/2W BAND,RSG-100(KITAGAWA)	4 4 2 9

• Parts with "⊙" indicate regular maintenance parts.